

High Output Benchtop Ionizer Installation, Operation and Maintenance



Figure 1. [60505](#) High Output Benchtop Ionizer

Description

The Desco [60505](#), High Output Benchtop Ionizer is a steady state DC, auto-balancing tabletop ionizer. A specially designed fan module creates better coverage (16" x 36"), consistent offset voltage (balance) ± 3 should be with a discharge times at less than one second at 12". The unit continually adjusts voltage output for optimal performance and automatically alarms when maintenance is needed or the unit is not operating correctly. Ionization offset voltage balance is consistent at all 3 speeds (50-100 CFM) and allows for use in sensitive applications, such as calibration, test, or repair procedures. The powder coated housing, multi-mount stand and sealed bearing fans minimize foreign objects debris, corrosion, and other contaminations when used in clean or or sensitive areas. Field replaceable emitter pins allow for replacement without returning to the factory.

"Necessary non-conductors in the environment cannot lose their electrostatic charge by attachment to ground. Ionization systems provide neutralization of charges on these necessary non-conductive items (circuit board materials and some device packages are examples of necessary non-conductors). Assessment of the ESD hazard created by electrostatic charges on the necessary nonconductors in the work place is required to ensure that appropriate actions are implemented, commensurate with risk to ESDS [ESD sensitive] items". (ANSI/ESD S20.20-2007 Foreword)

"In order to mitigate field-induced CDM [Charged Device Model] damage, the ESD program shall include a plan for the handling of

process-required insulators. If the field exceeds 2,000 volts/inch, steps shall be taken to either: A) Separate the insulator from the ESD-sensitive device by a distance of 30 cm (12 inches); or B) Use ionization or other charge mitigating techniques to neutralize the charge." (ANSI/ESD S20.20-2007 section 8.3)

"The primary method of static charge control is direct connection to ground for conductors, static dissipative materials, and personnel. A complete static control program must also deal with isolated conductors that cannot be grounded, insulating materials (e.g., most common plastics), and moving personnel who cannot use wrist or heel straps or ESD control flooring and footwear. Air ionization is not a replacement for grounding methods. It is one component of a complete static control program. Ionizers are used when it is not possible to properly ground everything and as backup to other static control methods. In clean rooms, air ionization may be one of the few methods of static control available." (ESD Handbook ESD TR20.20 Ionization, section 5.3.6.1)

"All ionization devices will require periodic maintenance for proper operation. Maintenance intervals for ionizers vary widely depending on the type of ionization equipment and use environment. Critical clean room uses will generally require more frequent attention. It is important to set-up a routine schedule for ionizer service. Routine service is typically required to meet quality audit requirements." (ESD Handbook ESD TR20.20 section 5.3.6.7 Maintenance / Cleaning)



CSA International tests products for compliance to national and international standards, and issues certification marks for qualified products. The certification marks tell potential customers and users that a product has been evaluated by a formal process-involving examination, testing and follow-up inspection-and that it complies with applicable standards for safety and performance.

<http://www.csa-international.org/>

High Output

- 1 Benchtop Ionizer with stand
- 1 Power Cord
- 1 Emitter Point Cleaner Pack (Item [60506](#))
- 1 Certificate of Calibration

Input Voltage

WARNING - RISK OF ELECTRIC SHOCK

THESE SERVICING INSTRUCTIONS ARE FOR USE BY QUALIFIED PERSONNEL ONLY. DO NOT PERFORM ANY SERVICING OF INTERNAL PARTS UNLESS YOU ARE QUALIFIED TO DO SO.

NOTE: THE AC POWER CORD MUST ALWAYS BE DISCONNECTED BEFORE THE UNIT IS DISASSEMBLED. UNIT SHIPPED SET AT 110V

The input voltage may be verified or changed to 220V by removing the 3 screws located on the back of the unit then removing the back case.

Input voltage is selected with two internal jumpers on JH1. For 110 volt jumper setting, a jumper must be in place shorting pin 1 to 2 and another shorting pin 3 to 4 (see figure 2). For 220 volt jumper setting, a single jumper must be in place shorting 2 to 3 only (see Figure 3). Make sure settign is correct before applying power

Before installing the unit, verify that the AC outlet is properly connected to ground. The unit must have a good ground to maintain proper offset voltage balance. Install the unit in the desired location, making sure that the airflow will not be restricted. Be sure the "OFF / ON" switch located on the rear of the unit is in the OFF position. Plug the power cord into the unit and then into the appropriate AC power source.

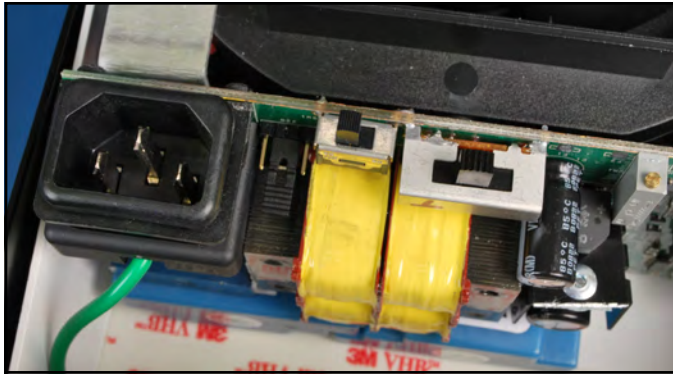

Figure 2. 110 Volt Jumper Setting



Figure 3. 220 Volt Jumper Setting

Operation

Set the fan speed switch on the rear of the unit to the LOW, MED, or HIGH position. Higher airflow will result in faster discharge times. Position the unit so that the maximum airflow is directed at the items or area to be neutralized. Turn the unit ON. When the unit is first turned on, it will conduct a self-test. The audible alarm will sound and then the LED will cycle through RED, YELLOW, and GREEN. The LED will remain GREEN during normal operation.



Figure 4. Front and Back High Output Benchtop Ionizer

Angle Adjustment Knobs - The angle of the fan may be adjusted to direct the airflow in the optimum coverage area.

Visual Alarm -

- GREEN - Normal Operation
- RED - Ionizer needs maintenance. Voltage supply has dropped below normal

Fan Guard Screws -

- May be removed ONLY when unit is disconnected from power for cleaning

Front Fan Guard -

- May be removed ONLY when unit disconnected from power for cleaning

Back Fan Guard -

- May be removed ONLY when unit disconnected from power for cleaning

IEC Cord Connection -

- AC line power, 120 VAC, 50/60Hz (Can be changed internally to 220V)

On/Off Switch

- Ionizer maybe turned when not in use.

Fan Speed Adjustment

- 3 position fan speed: Low, Medium, High (50-100CFM)

Balance Adjustment

- See Calibration/Maintenance section

If the supply voltage drops from 120 Volts to below 85 Volts, the unit will shut down, the audible alarm will beep, and the LED will blink RED. The unit will automatically reset when the minimum voltage is restored. Under normal conditions the ionizer will attract dirt and dust (especially on the emitter electrodes). To maintain optimum neutralization efficiency and operation, cleaning should be performed on a regular basis. When the unit enters shutdown mode, ionization will be stopped, the LED on the front of the unit

will change to a steady RED, and the audible alarm will sound continuously. If the ionizer enters shutdown mode, it must be turned OFF and then back ON to reset the unit. (See following Calibration section for more info.)

In the event of circuit failure, the unit will enter shutdown mode. When the unit enters shutdown mode, ionization will be stopped, the LED on the front of the unit will illuminate a constant red, and the audible alarm will continuously sound. The user must then reset the unit by turning it OFF and back ON.



Figure 5 Cleaning the Emitter Points

Cleaning the Emitter Points

Turn electrical power OFF.

- I. Turn the unit OFF and unplug the power cord.
- II. Remove the rear screen by removing the 4 screws. See Figure 5
- III. Clean the emitter points using the included 60506 Emitter Point Cleaners or a swab dampened with Isopropyl alcohol
- IV. Reattach the rear screen.
- V. Plug in the power cord and turn the unit ON.
- VI. Verify the offset voltage balance of the ionizer by using a charge plate monitor or ionization test kit.

The emitter electrodes should not require replacement during the life of the unit with normal handling. If necessary, item 60507 Replacement Emitter Points are available for order.

ESD TR53 does not advise a test frequency for ionizers. Your maintenance schedule will depend on the requirements of your ESD Control Plan. In order to manage service intervals, Desco recommends assigning a number or other identification method for each ionizer in your Maintenance / Calibration schedule. You may choose to use the ionizer's serial number for identification, as it is a unique number for identification, as it is a unique number that can be traced to when the ionizer was manufactured.

Neutralization (Discharge) Times

The comparative efficiency of overhead ionizers is determined by a standard test published by ANSI/ESD S3.1. Typical positive and negative discharge times (in seconds from 1000 volts to 100 volts and from -1000 volts to -100 volts) measured using this standard are shown below. The performance of the ionizer was measured with the unit positioned as shown, with the fan speed on high, and without a filter.

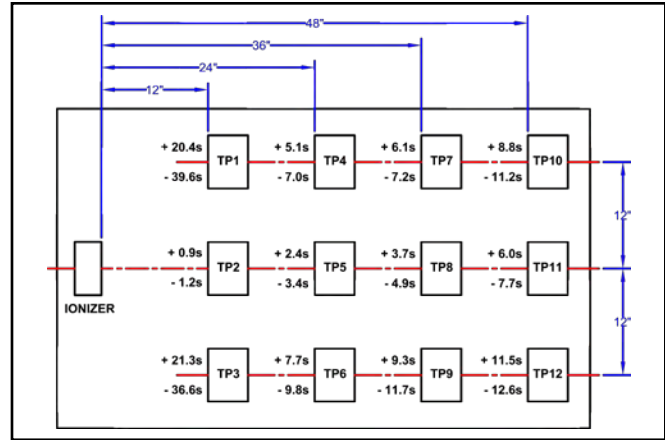

Figure 6. Neutralization (discharge) times

The typical discharge times measured using this standard for the ionizer are shown in the following diagram. They are not guaranteed maximum discharge times
Note: Reference ANSI/ESD STM 3.1. At room ambient temperature and relative humidity.

Specifications:

AIR FLOW

Three speed fans (50-100 cfm)

OFFSET VOLTAGE BALANCE

±10 volt, typical; ±20 volts maximum at 65°F to 80°F, R.H.: 15% to 65%

CHASSIS

White powder coated steel housing

DIMENSIONS - 60473

9.5" H x 6.0" W x 3.1" L (24.1cm H x 15.2cm W x 7.9 cm L)

EMITTER POINTS

.050" diameter pure tungsten for improved mechanical strength and ionization stability

FUSE

400mA slow blow

HIGH VOLTAGE POWER SUPPLY

5.5 kV DC nominal

INPUT POWER

AC line power, 120 VAC, 50/60Hz or 220/230 VAC 50/60Hz

ION EMISSION

Steady state DC with sense feedback

MOUNTING

Multi-Mount Stand

OZONE

Less than 0.05ppm

WEIGHT - 60473

4.5 lbs. (2.04 kg)

Compliance Verification

ANSI/ESD S20.20-2007 added Compliance Verification columns to the Tables. The test method for Compliance Verification is ESD TR53. Ionizers should be tested periodically for both polarity's discharge times, and for offset voltage balance per ESD Association Technical Report ESD TR53 Compliance Verification of ESD Protective Equipment and Materials. The most accurate tool to use for this is a Charged Plate Monitor. Alternatively, a portable battery operated Ionization Test Kit can be used.

Per ESD TR 53 ANNEX A "Test Frequency, The objective of the periodic test procedures listed in this document is to identify if significant changes in ESD equipment and materials performance have occurred over time. Test frequency limits are not listed in this document, as each user will need to develop their own set of test frequencies based on the critical nature of those ESD sensitive items handled and the risk of failure for the ESD protective equipment and materials."

Per ESD TR53, all the test locations of S3.1 are not required; rather "Measurements should be made at the location where ESD sensitive items are to be ionized. For many EPA ESD Control items sampling is appropriate for Compliance Verification, however, best practice is to test each ionizer.

NIST Calibration

Desco provides a basic, National Institute of Standards and Technology (NIST) traceable calibration for the products that we manufacture. This is sometimes referred to as a Level 1 calibration.

For more on National Institute of Standards and Technology see: <http://www.nist.gov/index.html>

For more information on the calibration that Desco's provides for products that we manufacture see: <http://www.desco.com/Calibration.aspx>

Calibration / Offset Voltage Balance Adjustment

When an alarm sounds, most users will clean emitter pins (see Maintenance / Alarms section) and calibrate the ionizer. Per ESD TR 53 section 5.3.6.7.1 "The best practice is to measure the offset voltage and discharge times, clean the unit, including emitter points and air filters if present, offset voltage to zero (if adjustable), and then repeat offset voltage and discharge time testing. If the unit does not meet offset voltage specifications or minimum established discharge time limits, further service is indicated. Manufacturers should provide details on service procedures and typical service intervals."

JESDD625-A (Revision of EIA-625) recommends ionizers be tested semiannually, noting to use "S3.1 except the number of measurement points and locations may be selected based on the application."

NOTE: A charged plate analyzer or monitor should be used in order to properly calibrate the Chargebuster High Outfit Benchtop ionizer. EMIT offers the [50555](#) Charged Plate Analyzer.

- I. Properly setup the ionizer as described in the Installation procedure on page 1.
- II. Turn the unit ON and set the FAN SPEED to HIGH.

- III. Position the charged plate analyzer 18 inches away from High Output Benchtop Ionizer.
- IV. The offset voltage balance should be within 0 ± 15 volts. The required limit per ANSI/ESD S20.20 is less than ± 50 volts. To increase the output in a positive direction, turn the BALANCE ADJUST potentiometer in a clockwise direction. To increase the output in a negative direction, turn the BALANCE ADJUST potentiometer in a counter clockwise direction.
- V. Test the neutralization discharge time by applying a $\pm 1,000$ volt on the charged plate. Do both \pm polarities. The neutralization (discharge) time should be less than 3 seconds. See figures 4 for typical discharge times. The required limit per ANSI/ESDS20.20 is "user defined".
- VI. Submit the offset voltage balance to the ionizer's control circuit by quickly pressing the ALARM RESET button. The STATUS LED should turn off and then illuminate green to verify that the control circuit was successfully programmed.
- VII. Test each fan's alarm by shorting its two grills located on the bottom side of the ionizer (see Figure 8). The alarm should sound and the STATUS LED should illuminate red.

Health

There are no known health risks associated with our devices. The emitters work at about 4-6 kV and can create ozone, but there have been no significant measurement of ozone from our emitter sets as all our existing units test well below the OSHA limit of 0.05 ppm ozone. For additional safety information, see "Dispelling an Old Myth" written by William Metz of Hewlett-Packard published in Evaluation Engineering magazine September 2001.



Figure 7. [60505](#) Shorting the Ionizer's two fan grills

Limited Warranty

Desco expressly warrants that for a period of one (1) year from the date of purchase, Desco High Output Benchtop Ionizers will be free of defects in material (parts) and workmanship (labor). Within the warranty period, a unit will be tested, repaired or replaced at Desco option, free of charge. Call Customer Service at 909-627-8178 for Return Material Authorization (RMA) number and proper shipping instructions and address. Any unit under warranty should be shipped prepaid to the Desco factory. Include a copy of your original packing slip, invoice, or other proof of purchase date. Warranty repairs will take approximately two weeks.

If your unit is out of warranty, Desco will quote repair charges necessary to bring your unit up to factory standards. Call Customer Service at 909-627-8178 for an RMA number and proper shipping instructions, and ship your unit freight prepaid.

Warranty Exclusions

THE FOREGOING EXPRESS WARRANTY IS MADE IN LIEU OF ALL OTHER PRODUCT WARRANTIES, EXPRESSED AND IMPLIED, INCLUDING MERCHANTABILITY AND FITNESS FOR A PARTICULAR PURPOSE WHICH ARE SPECIFICALLY DISCLAIMED. The express warranty will not apply to defects or damage due to accidents, neglect, misuse, alterations, operator error, or failure to properly maintain, clean or repair products.

Limit of Liability

Electronic ionizers use high voltage corona discharge and should not be used in or near flammable or explosive environments. In no event will Desco or any seller be responsible or liable for any injury, loss or damage, direct or consequential, arising out of the use of or the inability to use the product. Before using, users shall determine the suitability of the product for their intended use, and users assume all risk and liability whatsoever in connection therewith.